

## 60V N-Channel Enhancement Mode MOSFET

### 1. Product Information

#### 1.1 Features

- ◇ Advanced SGT cell design
- ◇ Low Gate Charge
- ◇ Low On-Resistance
- ◇ RoHS and Halogen-Free Compliant
- ◇ 100%  $\Delta V_{DS}$  & UIS & Rg Tested

#### 1.2 Applications

- ◇ DC-DC Converter
- ◇ Drones
- ◇ Motor drivers
- ◇ Light electric vehicles

#### 1.3 Quick reference

- ◇  $BV \cong 60\text{ V}$
- ◇  $P_{\text{tot}} \cong 555\text{ W}$
- ◇  $I_D$  (Silicon Limited)  $\cong 1051\text{ A}$
- ◇  $I_D$  (Package Limited)  $\cong 500\text{ A}$
- ◇  $R_{DS(ON)} \cong 0.4\text{ m}\Omega @ V_{GS} = 10\text{ V}$
- ◇  $R_{DS(ON)} \cong 0.7\text{ m}\Omega @ V_{GS} = 6\text{ V}$



### 2. Pin Description

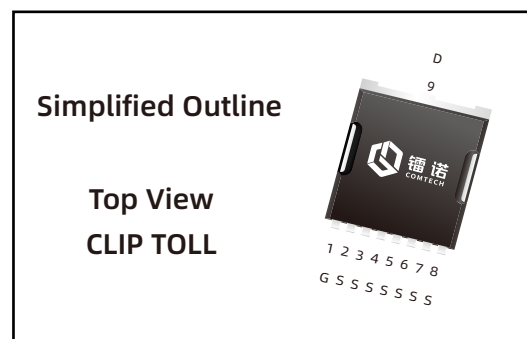
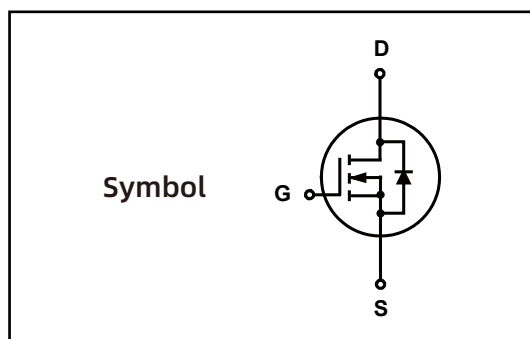

## 3.Limiting Values

Symbol	Parameter	Conditions	Min	Max	Unit	Note
$V_{DS}$	Drain-Source Voltage	$T_C = 25\text{ }^\circ\text{C}$	-	60	V	-
$V_{GS}$	Gate-Source Voltage	$T_C = 25\text{ }^\circ\text{C}$	-	$\pm 20$	V	-
$I_D^*$	Drain Current ( DC ) (Silicon Limited)	$T_C = 25\text{ }^\circ\text{C}, V_{GS} = 10\text{ V}$	-	1051	A	Fig.2
		$T_C = 100\text{ }^\circ\text{C}, V_{GS} = 10\text{ V}$	-	743	A	
	Drain Current ( DC ) (Package Limited)	$T_C = 25\text{ }^\circ\text{C}, V_{GS} = 10\text{ V}$	-	500	A	
		$T_C = 100\text{ }^\circ\text{C}, V_{GS} = 10\text{ V}$	-	354	A	
$I_{DM}^{**},^{***}$	Drain Current ( Pulsed )	$T_C = 25\text{ }^\circ\text{C}, V_{GS} = 10\text{ V}$	-	1549	A	-
$P_{tot}$	Drain power dissipation	$T_C = 25\text{ }^\circ\text{C}$	-	555	W	Fig.1
		$T_C = 100\text{ }^\circ\text{C}$	-	277	W	
$T_{stg}$	Storage Temperature		-55	175	$^\circ\text{C}$	-
$T_J$	Junction Temperature		-	175	$^\circ\text{C}$	-
$I_S$	Continuous-Source Current	$T_C = 25\text{ }^\circ\text{C}$	-	500	A	-
$E_{AS}^*$	Single Pulsed Avalanche Energy	$V_{DD} = 60\text{ V}, L = 1\text{ mH}$	-	5832	mJ	Fig.19

## 4.Thermal Characteristics

$R_{\theta JA}^*$	Thermal Resistance- Junction to Ambient	-	13	$^\circ\text{C}/\text{W}$	Fig.16
$R_{\theta JC}^*$	Thermal Resistance- Junction to Case	-	0.27		

Notes :

\* Surface Mounted on 1 in<sup>2</sup> pad area, t ≤ 10 sec

\*\* Pulse width ≤ 300 μs, duty cycle ≤ 2 %

\*\*\* limited by bonding wire

## 5.Marking Information

Product Name	Package	Reel size	Tape width	Quantity	Note
LNR35N060CT-H	CLIP TOLL	330mm	24mm	2000	

Note: COMTECH defines " Green " as lead-free ( RoHS compliant ) and halogen free ( Br or Cl does not exceed 900 ppm by weight in homogeneous material and total of Br and Cl does not exceed 1500 ppm by weight; Follow IEC 61249-2-21 and IPC / JEDEC J-STD-020C )

## 6. Electrical Characteristics ( $T_A=25^\circ$ Unless Otherwise Noted )

Symbol	Parameter	Conditions	Min	Typ	Max	Unit	Note
<b>Static Characteristics</b>							
$BV_{DSS}$	Drain-Source Breakdown Voltage	$V_{GS} = 0\text{ V}, I_{DS} = 250\ \mu\text{A}$	60	-	-	V	
$V_{GS(th)}$	Gate Threshold Voltage	$V_{DS} = V_{GS}, I_{DS} = 250\ \mu\text{A}$	2	-	4	V	
$I_{DSS}$	Drain Leakage Current	$V_{DS} = 60\text{ V}, V_{GS} = 0\text{ V}$	-	-	1	$\mu\text{A}$	
$I_{GSS}$	Gate Leakage Current	$V_{GS} = \pm 20\text{ V}, V_{DS} = 0\text{ V}$	-	-	$\pm 100$	nA	
$R_{DS(on)}^a$	On-State Resistance	$V_{GS} = 10\text{ V}, I_{DS} = 50\text{ A}$	-	0.3	0.4	m $\Omega$	Fig.8
		$V_{GS} = 6\text{ V}, I_{DS} = 30\text{ A}$	-	0.6	0.7		
<b>Diode Characteristics</b>							
$V_{SD}^a$	Diode Forward Voltage	$I_{SD} = 50\text{ A}, V_{GS} = 0\text{ V}$	-	-	1.3	V	Fig.7
$t_{rr}$	Reverse Recovery Time	$I_{DS} = 50\text{ A}, V_{GS} = 0\text{ V}$	-	89	-	nS	Fig.20
$Q_{rr}$	Reverse Recovery Charge	$dI_{SD}/dt = 100\text{ A}/\mu\text{s}$	-	499	-	nC	
<b>Dynamic Characteristics<sup>b</sup></b>							
$C_{iss}$	Input Capacitance	$V_{GS} = 0\text{ V}, V_{DS} = 30\text{ V}$ Frequency = 1 MHz	-	16442	-	pF	Fig.10
$C_{oss}$	Output Capacitance		-	6649	-		
$C_{riss}$	Reverse Transfer Capacitance		-	497	-		
$R_G$	Gate Resistance	F= 1 MHz	-	2.4	-	$\Omega$	
$t_d(on)$	Turn-on Delay Time	$V_{DS} = 30\text{ V}, V_{GS} = 10\text{ V},$ $R_G = 2.7\ \Omega, R_L = 4\ \mu\text{H},$ $I_{DS} = 50\text{ A}$	-	53	-	nS	Fig.18
$t_r$	Turn-on Rise Time		-	183	-		
$t_d(off)$	Turn-off Delay Time		-	144	-		
$t_f$	Turn-off Fall Time		-	102	-		
$dv/dt$	Peak Diode Recovery		-	0.131	-		
$di/dt$	Peak Diode Recovery	-	341	-	A/ $\mu\text{s}$		
<b>Gate Charge Characteristics<sup>b</sup></b>							
$Q_g$	Total Gate Charge	$V_{DS} = 30\text{ V}, V_{GS} = 10\text{ V},$ $I_{DS} = 50\text{ A}$	-	288	-	nC	Fig.9
$Q_{gs}$	Gate-Source Charge		-	64	-		
$Q_{gd}$	Gate-Drain Charge		-	101	-		
$V_{plateau}$	Gate plateau voltage		-	4.5	-		

Notes :

a : Pulse test ; pulse width  $\leq 300\ \mu\text{s}$ , duty cycle  $\leq 2\%$

b : Guaranteed by design, not subject to production testing

## 7. Typical Characteristics

Fig.1 Power Capability

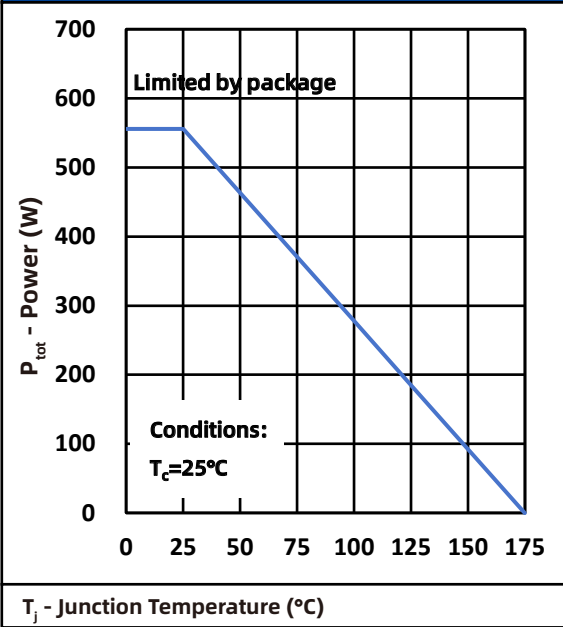

Fig.2 Current Capability

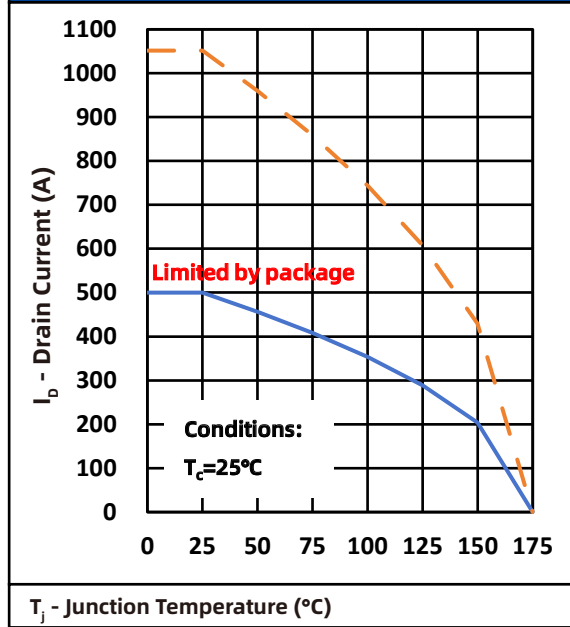

Fig.3 Output Characteristics@ $T_j$  -55°C

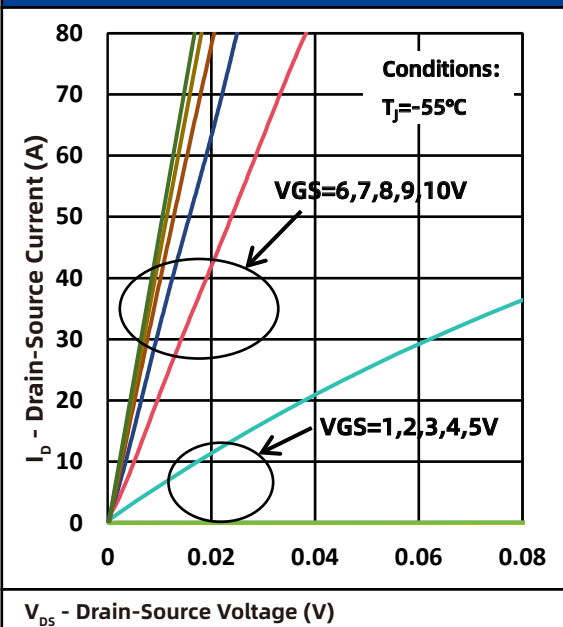
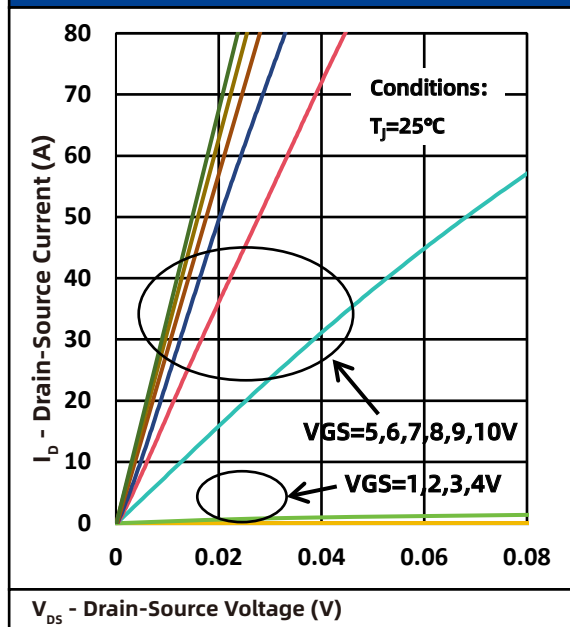
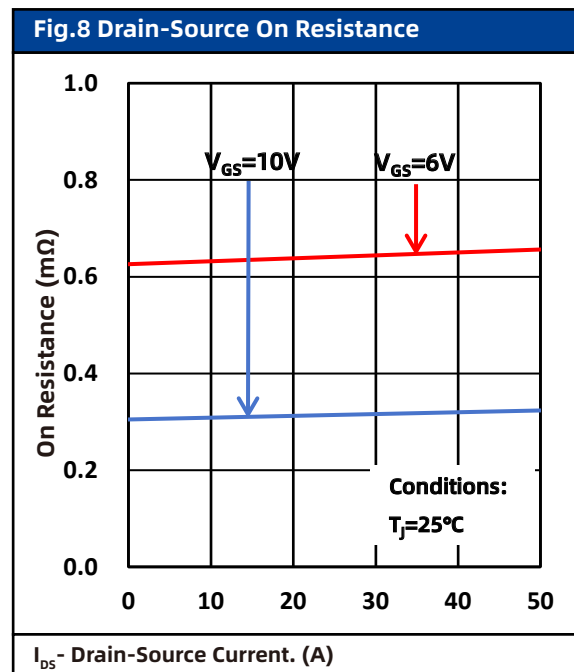
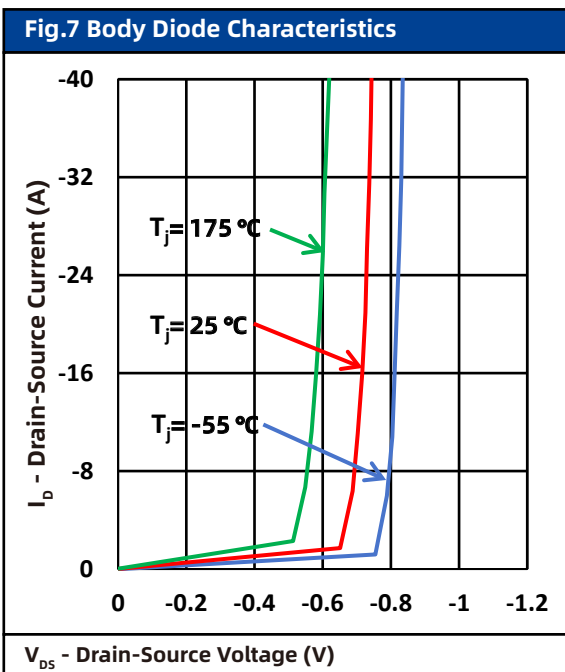
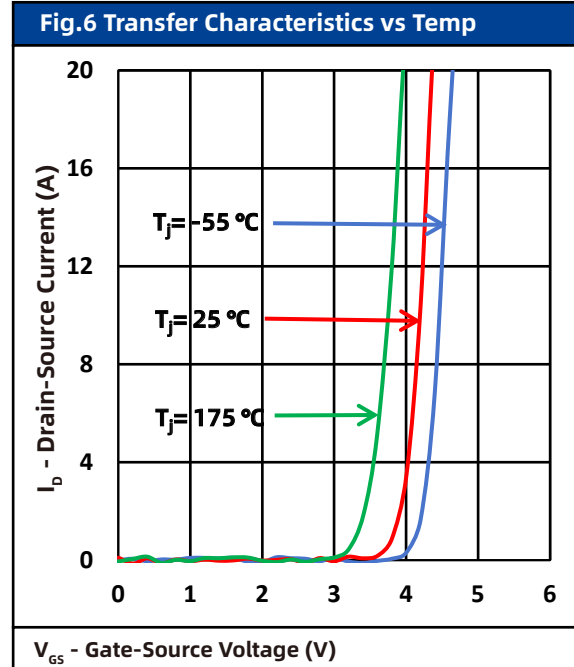
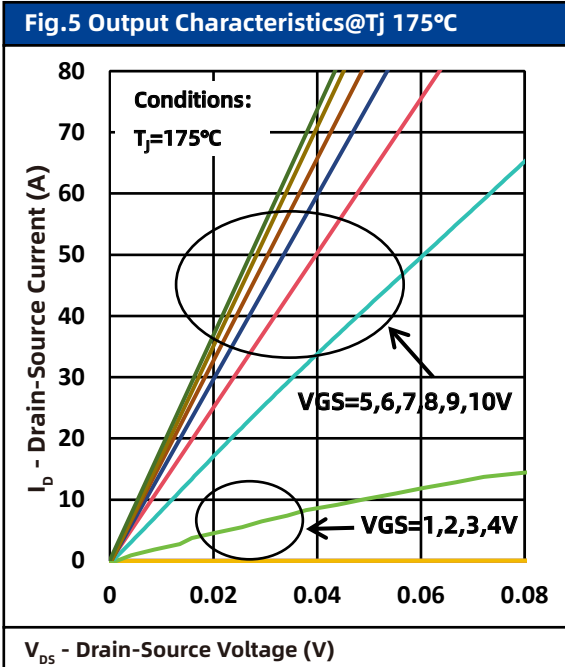

Fig.4 Output Characteristics@ $T_j$  25°C



## 7. Typical Characteristics



## 7. Typical Characteristics

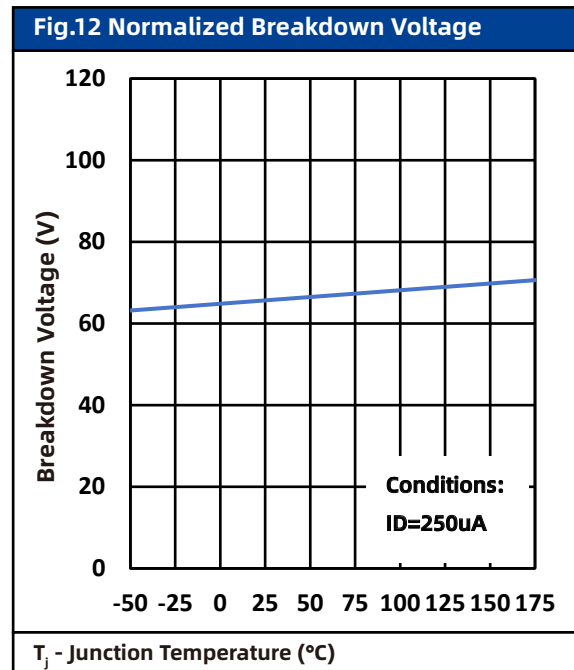
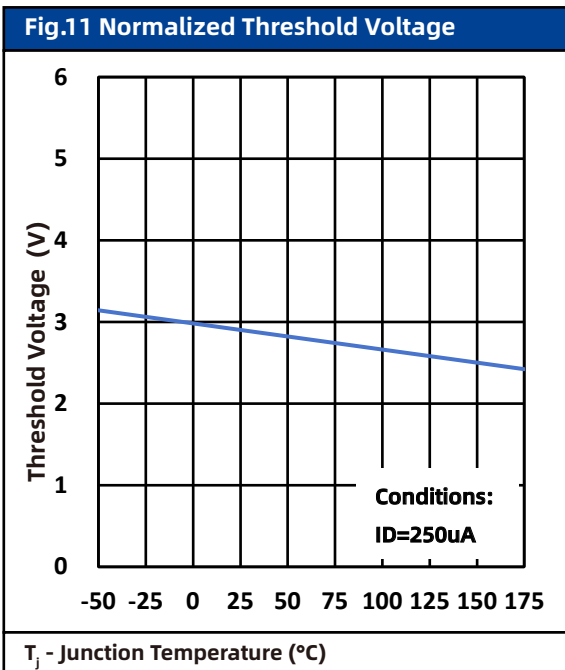
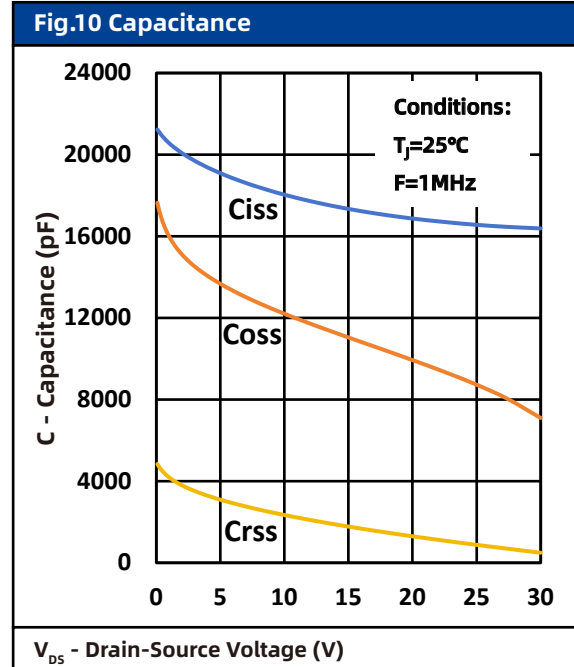
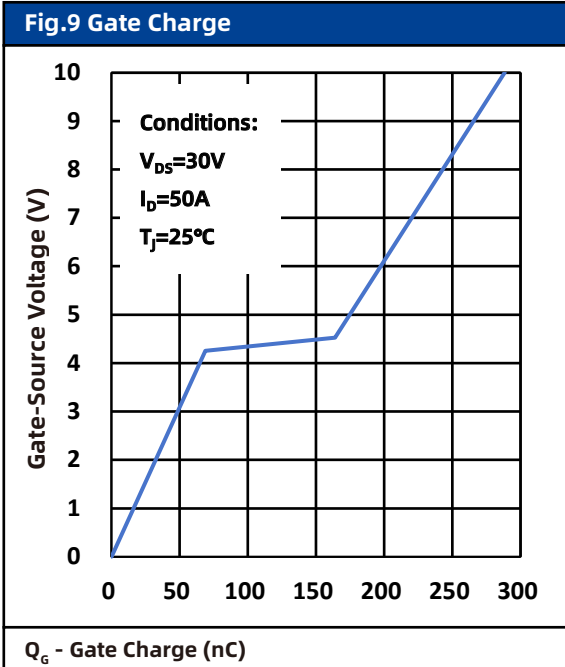

## 7. Typical Characteristics

Fig.13 Normalized On Resistance

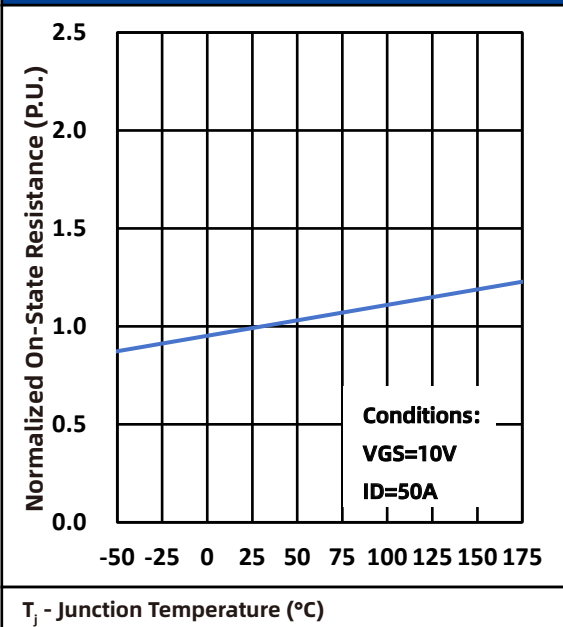

Fig.14 Switching Energy vs I<sub>D</sub>

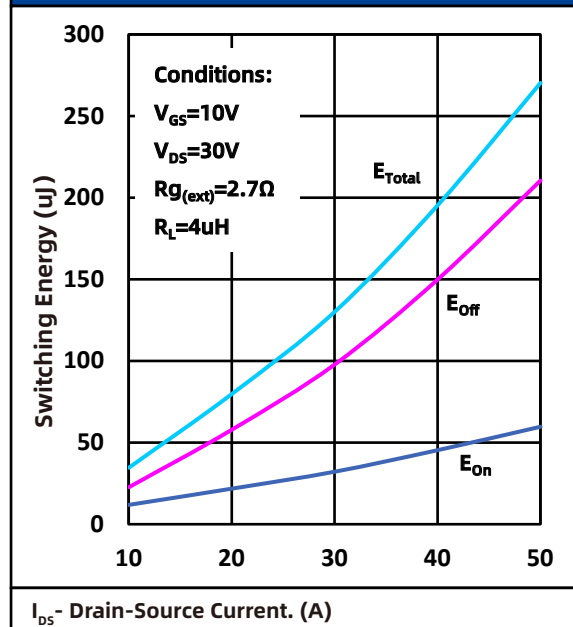

Fig.15 Safe Operating Area

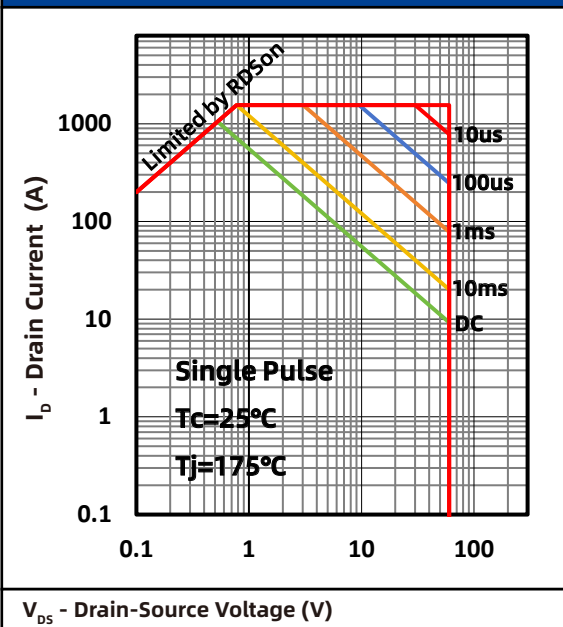
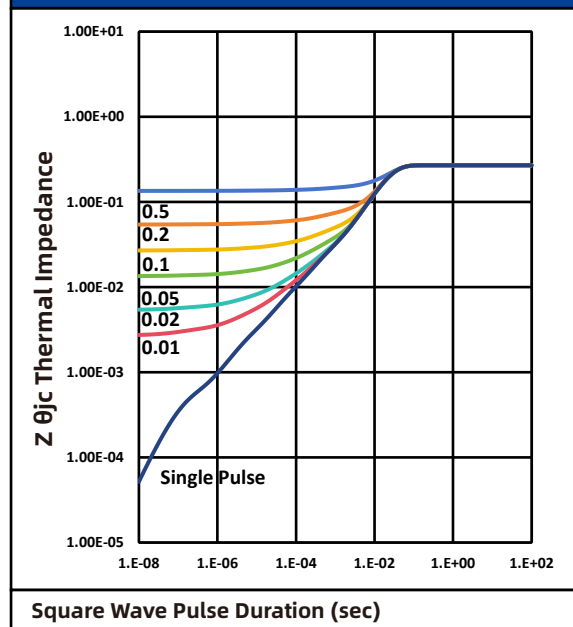

Fig.16 Transient Thermal Impedance



## 7. Typical Characteristics

Fig.17 Gate Charge Test Circuit & Waveform

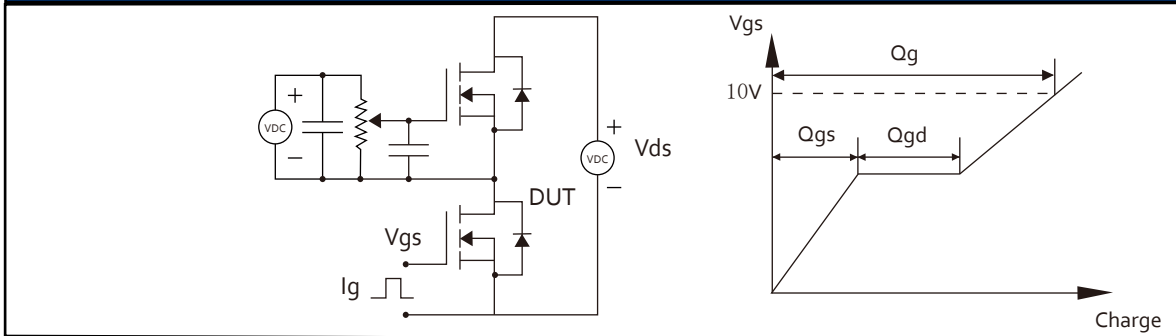

Fig.18 Resistive Switching Test Circuit & Waveforms

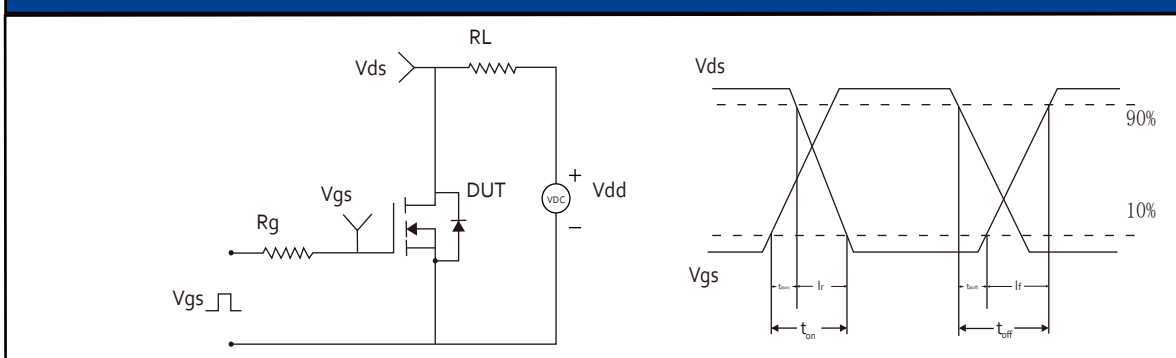

Fig.19 Unclamped Inductive Switching (UIS) Test Circuit & Waveforms

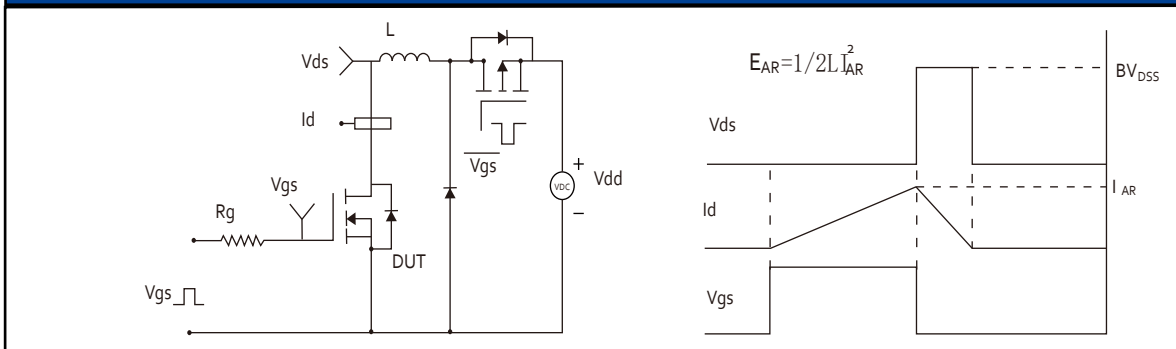
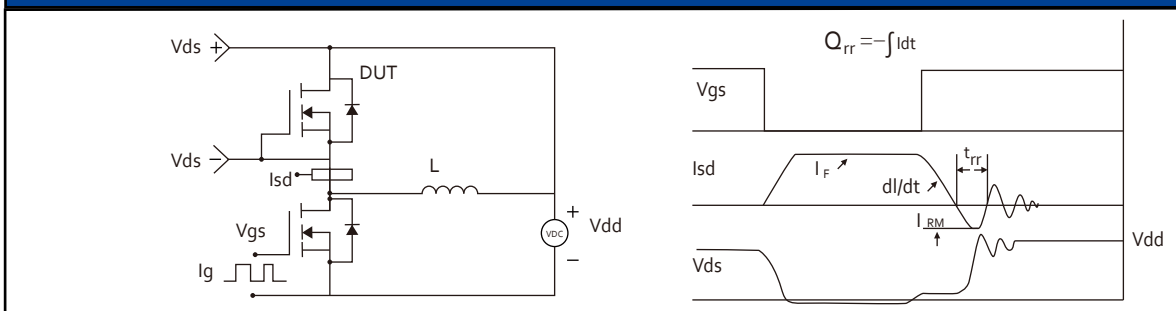
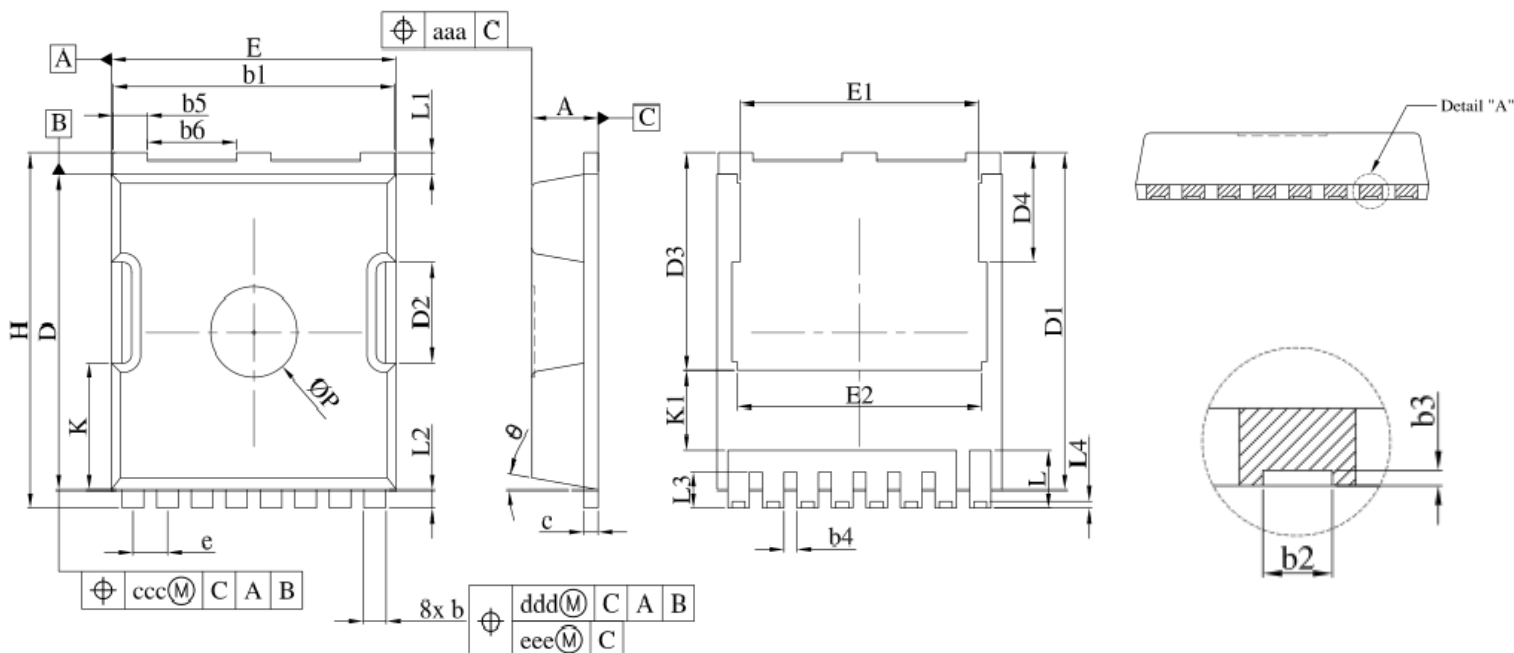

Fig.20 Diode Recovery Test Circuit & Waveforms



## 8. Package Dimensions

### CLIP TOLL Package



Symbol	Dimensions In Millimeters		
	MIN.	NOM.	MAX.
A	2.20	2.30	2.40
b	0.70	0.80	0.90
b1	9.70	9.80	9.90
b2	0.36	0.45	0.55
b3	0.05	0.10	0.35
b4	0.30	0.40	0.50
b5	1.10	1.20	1.30
b6	3.00	3.10	3.20
c	0.40	0.50	0.60
D	10.28	10.38	10.55
D1	10.98	11.08	11.18
D2	3.20	3.30	3.40
D3	7.00	7.15	7.30
D4	3.44	3.59	3.74
e	1.10	1.20	1.30
E	9.80	9.90	10.00
E1	8.20	8.30	8.40
E2	8.35	8.50	8.65
H	11.50	11.68	11.85
K	4.08	4.18	4.28
K1	2.45	-	-
L	1.60	1.90	2.10
L1	0.50	0.70	0.90
L2	0.50	0.60	0.70
L3	1.00	1.20	1.30
L4	0.13	0.23	0.33
P	2.85	3.00	3.15
θ		10°REF.	
aaa		0.20	
ccc		0.20	
ddd		0.25	
eee		0.20	

## 9. Record of Document amendment

产品名称: LNR35N060CT-H  
版权说明: 镭诺电子(宁波)有限公司  
联系电话: 4008887385

文档类型: 产品手册  
公司主页: [www.leinosemi.com](http://www.leinosemi.com)

版本: 01  
修改记录:  
1.初版发行